

REALFICTION™

# dreamoc™

A Cool New 3D Display that gives your product the competitive edge

In today's highly competitive retail market top end brands and exclusive stores need exciting new ways to differentiate themselves from the competition.

The Dreamoc, from RealFiction, is a unique 3D display unit that conveys compelling product messages that consumers just can't ignore.

Dreamoc provides a dazzling combination of holographic-like, free floating video images, with a display of the physical product. The video can be fully customized to fit your branding and colour.

Make your product stand out from the crowd with the powerful and eye-catching Dreamoc display.

## Features

- Visually stunning product display
- Generates positive attention
- Combines free-floating 3D elements and physical products
- Superior exposure and branding
- High reliability and long lifetime
- High brightness LED for product exposure

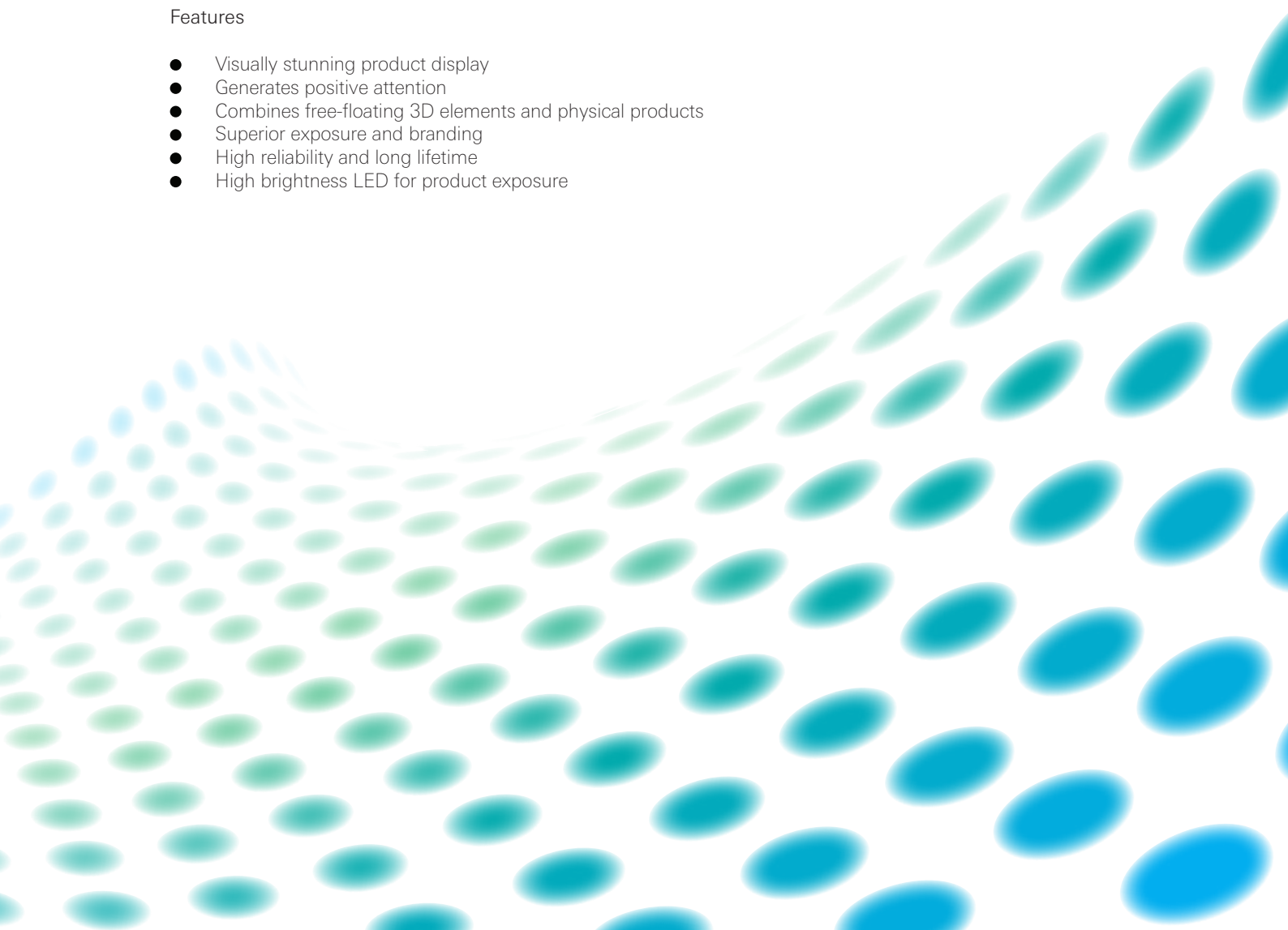











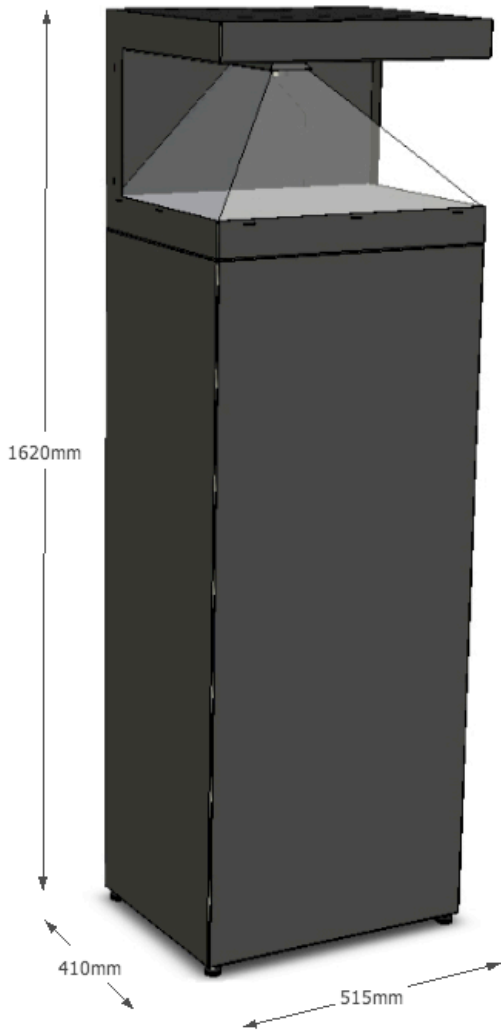

◀ Dreamoc Facts  
 Dimensions: L=515 mm, D=410 mm, H=1620 mm  
 Weight: 38 kg  
 1680x1050 resolution  
 Power: 100-240V ~ 50-60Hz  
 Energy Consumption: 60W

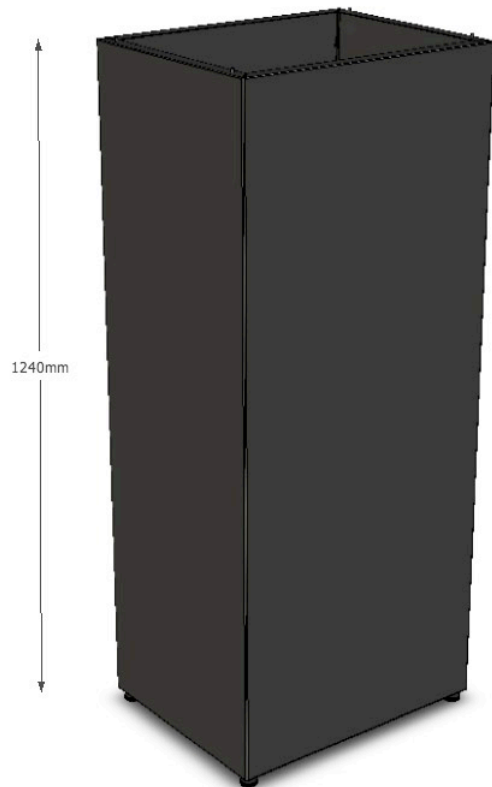

Stand Package Dimensions ▶  
 Weight: 20 kg

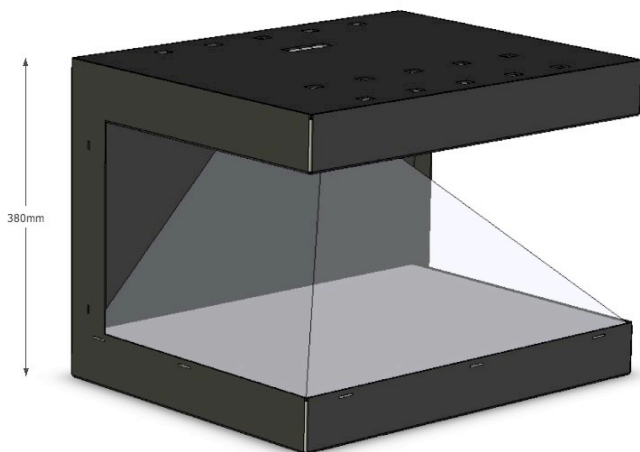
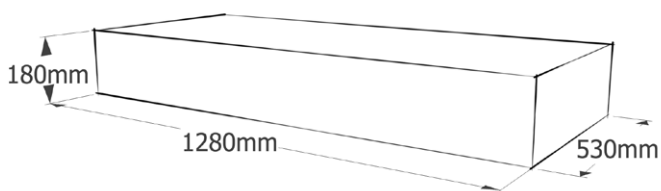

◀ Display Package Dimensions  
 Weight: 20kg

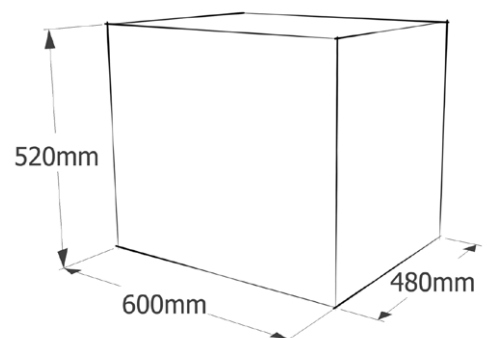



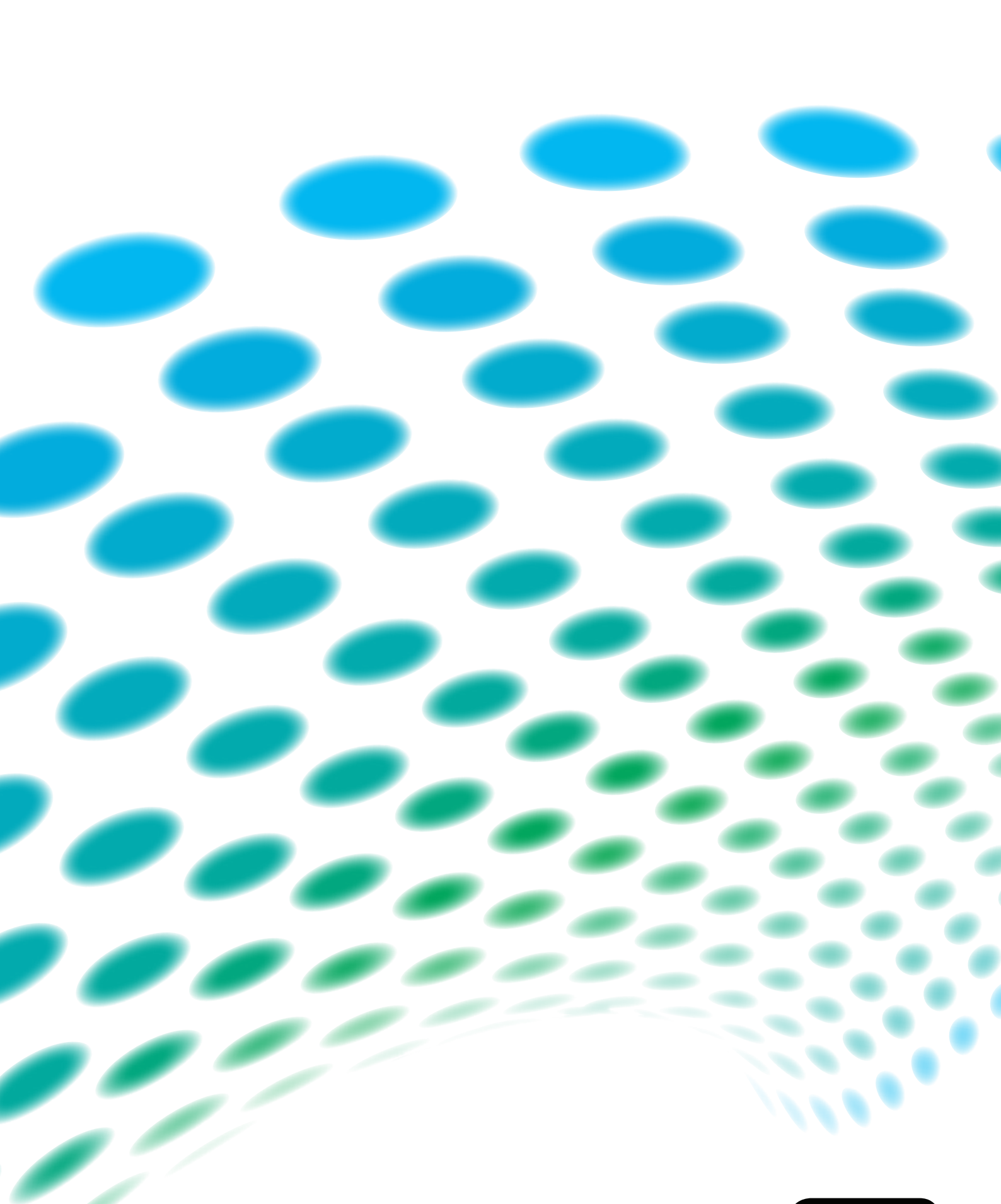

For further information and pricing  
please contact RealFiction  
phone number: +45 7020 6490  
email: [contact@realfiction.com](mailto:contact@realfiction.com)

